

# PSENmag

## PSEN 2.2p-20



### Unit features

- ▶ The actuator **PSEN 2,2-20** belongs to the safety switch
- ▶ 2 reed contacts (1 N/C, 1 N/O)
- ▶ Assured operating distance: **8 mm**
- ▶ Assured release distance: **26 mm**
- ▶ Round design
- ▶ Works magnetically
- ▶ Switching voltage 24 VDC
- ▶ Series connection via PSEN i1 interface

### Function description

If the actuator is within the response range, the magnets switch the reed contacts on the safety switch. If the actuator is outside the response range (safety gate open), the reed contacts on the safety switch will switch.

Magnetic safety switches for monitoring the position of movable guards in accordance with EN 60947-5-3

### Approvals

	PSEN 2.2p-20
	◆
	◆

### Unit description

The safety switch meets the requirements of EN 60204-1 and IEC 60204-1.  
 The safety switch only complies with EN 60947-5-3 in conjunction with the actuator **PSEN 2,2-20** and its approved evaluation devices.  
 The safety switch should only be connected to the evaluation devices listed under "Connections".

### Block diagram

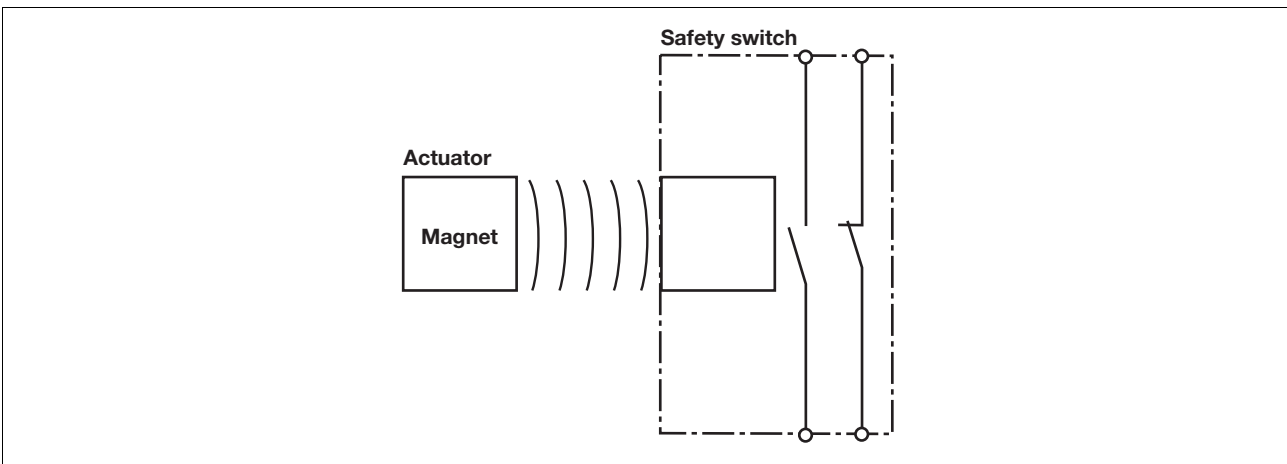

# PSENmag

## PSEN 2.2p-20

### Operating distances

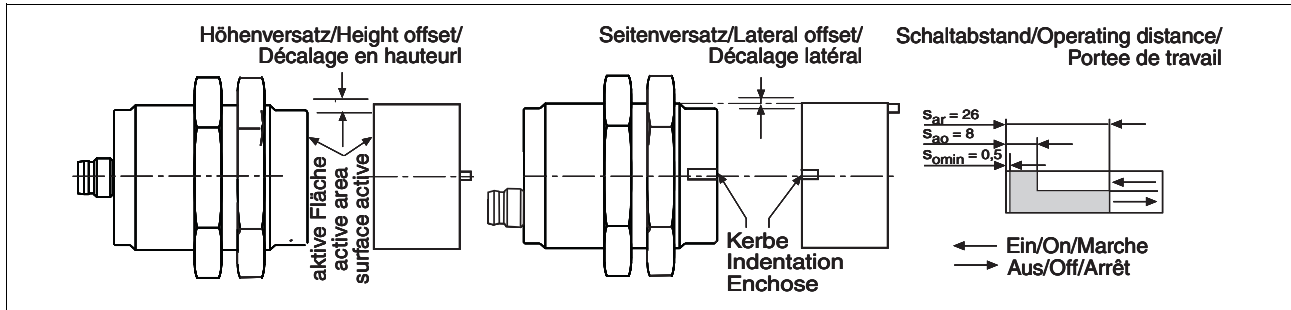

### Lateral and vertical offset

- Assured operating distance  $S_{ao}$  in mm

Höhenversatz/Height offset/ Décalage en hauteur		1,0	2,0	3,0	4,0	5,0
Seitenversatz/Lateral offset/Décalage latéral	1,0	7,5	7,5	7,0	7,0	5,5
	2,0	7,5	7,0	7,0	6,5	5,5
	3,0	7,0	7,0	7,0	6,0	5,5
	4,0	6,5	6,5	6,0	5,5	5,0
	5,0	6,0	6,0	6,0	5,0	4,5

- Assured release distance  $S_{ar}$ :  
Max. 26 mm with all vertical and lateral offsets

The stated values are valid at a temperature of 20 °C.

### Wiring

Please note:

- Information given in the “Technical details” must be followed.

- Calculation of the max. cable runs  $l_{max}$  in the input circuit:

$$l_{max} = \frac{R_{lmax}}{R_l / km}$$

$R_{lmax}$  = max. overall cable resistance (see Technical details)  
 $R_l / km$  = cable resistance/km

- When using evaluation devices with delay-on de-energisation contacts, please note:
  - Delay time  $\leq 30$  s: Delay-on de-energisation contacts satisfy the requirements of category 3 in accordance with EN 954-1 and the requirements of a PDF with single-fault tolerance (PDF-S).
  - Delay time  $\geq 30$  s: Delay-on de-energisation contacts satisfy the requirements of Category 1 in accordance with EN 954-1 and the requirements of a PDF with designed reliability (PDF-D).

- In the following commissioning cases, check the function that detects shorts across contacts:

- On evaluation devices with DC supply voltage: Overall cable resistance  $\geq 15$  Ohms per channel
- On evaluation devices with AC supply voltage: Overall cable resistance  $\geq 25$  Ohms per channel
- For details of how to perform the test for shorts across the contacts, please refer to the operating manual for the relevant evaluation device.

### Connections

#### NOTICE

The colour marking for the connection lead only applies for the cable that Pilz supplies as an accessory. The safety switch is shown in an unoperated condition.

Assignment of the 4-pin M8 male connector

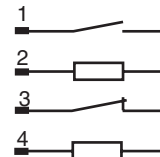

## PSENmag PSEN 2.2p-20

### ► Connection to PNOZelog

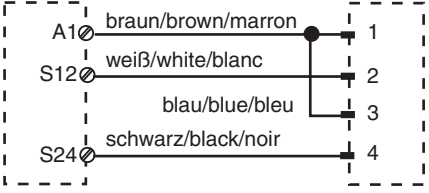
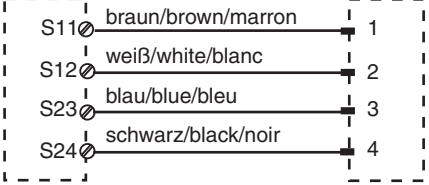
<p>ohne Querschlusserkennung/without detection of shorts across contacts/sans détection des courts-circuits entre les canaux PNOZ e3.1p PNOZ e3vp 10 s PNOZ e3vp 300 s</p>	
<p>mit Querschlusserkennung/with detection of shorts across contacts/avec détection des courts-circuits entre les canaux PNOZ e3.1p PNOZ e3vp 10 s PNOZ e3vp 300 s</p>	

### ► Connection to PNOZmulti

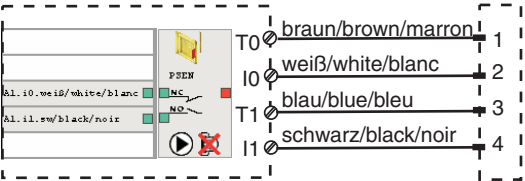
<p>Schutztür/safety gate/protecteur mobile Schaltertyp 2/switchtype 2/type du capteur 2 I0, I1: Eingänge/inputs/entrées T0, T1: Taktausgänge/test pulse outputs/sorties impulsionelles</p>	
--	---

### ► Connection to PSS with and without SafetyBUS p

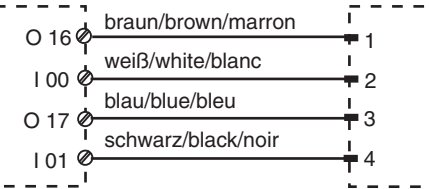
<p>Schutztür/safety gate/protecteur mobile Schaltertyp 3/switchtype 3/type du capteur 3 I0, I1: Eingänge/inputs/entrées O16, O17: Taktausgänge/test pulse outputs/sorties impulsionelles</p>	
--	--

### CAUTION!

The safety switches may only be operated on a PSS in conjunction with standard function block SB064 or SB066.

## PSENmag PSEN 2.2p-20

### Installation

- ▶ The unit can be installed in any position. However, the safety switch and actuator must be installed so that the two notches are exactly opposite each other (see diagram: "Operating distances").
- ▶ A nib on the actuator prevents it twisting (see diagram: "Dimensions"). Drill diameter: 2 mm.
- ▶ If possible, do not install the safety switch and actuator on to ferromagnetic material. Changes to the operating distances are to be expected.
- ▶ The torque setting for the M30 nuts is max. 300 Ncm.
- ▶ The actuator should be secured using an M4 or M5 screw made of non-magnetic material (e.g. Messing).
- ▶ The distance between two systems comprising safety switch and actuator must be at least 25 mm.
- ▶ Safety switch and actuator
  - Keep away from iron swarf
  - Do not expose to strong magnetic fields
  - Do not expose to heavy shock or vibration
  - Do not use as a limit stop

### Adjustment

- ▶ The safety switch may only be used with the corresponding actuator **PSEN 2,2-20**.
- ▶ Always test the function with one of the approved evaluation devices.
- ▶ The stated operating distances (see Technical details) only apply when the safety switch and actuator are installed facing each other in parallel. Switching distances may deviate if other arrangements are used. Note the maximum permitted lateral and vertical offset (see "Operating distances" and "Max. lateral and vertical offset").

## PSENmag

### PSEN 2.2p-20

#### NOTICE

This data sheet is only intended for use during configuration. For installation and operation, please refer to the operating instructions supplied with the unit.

#### Dimensions

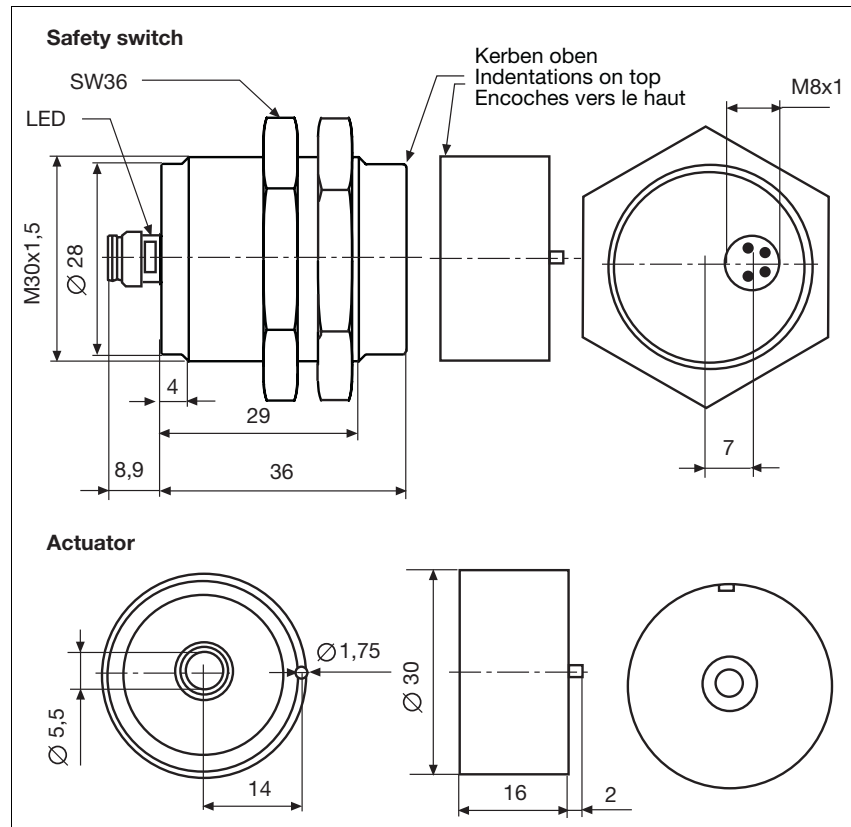

#### Technical details

Switching distances	
Assured operating distance $S_{ao}$	8 mm
Min. operating distance $S_{omin}$	0.5 mm
Assured release distance $S_{ar}$	26 mm
Switching voltage	24 V
Max. switching current for reed contacts	10.00 mA
Max. breaking capacity for reed contacts	0.3 W
Max. switch frequency	1 Hz
Actuator	PSEN 2,2-20
Ambient temperature	-25 - 70 °C
Vibration to <b>EN 60947-5-2</b>	
Frequency	10 - 55 Hz
Amplitude	1.00 mm
Shock stress	30 g , 11 ms
Connection type	M8
Cable	LiYY 4 x 0,25 mm <sup>2</sup>
Protection type	IP65, IP67
Housing material	PBT

## PSENmag

### PSEN 2.2p-20

#### Technical details

Dimensions	
Diameter	<b>M30</b>
Safety switch	
Depth	<b>42.7 mm</b>
Actuator	
Depth	<b>16 mm</b>
Weight	
Safety switch	<b>35 g</b>
Actuator	<b>20 g</b>

The standards current on **2007-03** apply.

#### Order reference

Type	Quantity	Operation	Features	Order no.
PSEN 2.2p-20	1/1	magnetic	Safety switch/actuator	503 220
PSEN 2.2p-20 (switch)	1	magnetic	Safety switch	523 120
PSEN 2.2-20	1	magnetic	Actuator	513 120